

CONGRATULATIONS

You are now the proud owner of a Nordic by IMG.
We are confident you will enjoy the comfort and style of this new furniture.

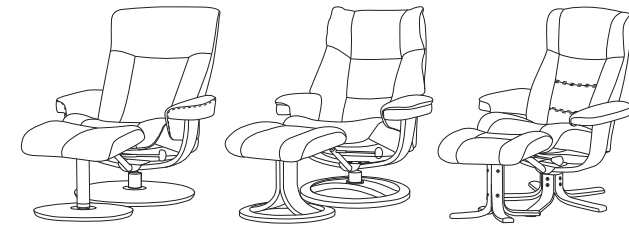

IMPORTANT

Read this and other relevant instructions before using the product. Keep this manual for future reference.

SAFETY INSTRUCTIONS

GENERAL WARNINGS:

Never drag furniture when moving it, always lift it.
Periodically check all fixings to ensure none have come loose and re-tighten where necessary.
Please take care when handling or moving the furniture as careless handling may cause damage or injury. Furniture can be dangerous if incorrectly installed. Assembly should be carried out by a competent person. No liability will be accepted for damage or injury caused by incorrectly installed or assembled furniture.

SPECIFIC WARNINGS FOR HEAVY ITEMS:

It is recommended that before moving heavy objects to a new location they are completely dis-assembled to avoid personal injury or damage to the furniture. Please be careful to retain all fittings when doing this.

CHAIR SPECIFIC WARNINGS:

Never tilt the chair. Ensure the chair is always placed firmly on the ground.

IMPORTANT SAFETY NOTE:

Do Not:
Use the stool as a ladder
Climb on the stool
Stand on the foot-rest of the stool, as this could lead to the stool becoming unbalanced and overturning.

WARNING:

- Do not sit on the armrest or chair footstool/ ottoman.
- Do not stand on the chair footstool/ ottoman.
- Do not use the chair footstool/ ottoman as a step ladder.
- Do not use this chair unless all bolts, screws and knobs are firmly secured.
- At least every 4 months – check all bolts, screws and knobs to be sure that they are tight.
- If parts are missing, broken, damaged or worn – stop use of the product until repair are made, using factory authorized parts only.
- For further information see care manual and assembly instruction.
- Failure to follow these warnings could result in serious injury.

PLEASE KEEP THESE INSTRUCTIONS FOR FUTURE REFERENCE

IMG recommends adding felt pads as an extra precaution beneath each of the five legs on Star bases to prevent damage to flooring.

CARE AND MAINTENANCE

WOOD CARE

All timber surfaces will change colour and mellow over time.
New furniture will initially vary in shade from items that have been previously purchased.

TIMBER/ WOOD CARE

- Wood and frame surfaces require regular dusting.
- When cleaning is needed, use a damp cloth followed by a dry cloth.
- Remove liquid spills or dirt immediately from the frame and mechanism parts.

Spray polishes are best avoided as they contain silicones which may spoil the furniture's surface by building up over time.

Make sure all surfaces are protected from heat and liquids by mats and coasters. Wipe up spills immediately and ensure that a mat or pad is placed under paper if you are writing.

Our furniture will endure most temperatures in the home but it is best to avoid placing furniture next to heat sources such as radiators or fires. Be particularly careful with solid wood as the lack of humidity caused by central heating can cause damage such as warping

LEATHER CARE

Protect leather from spillage, sunlight and heat. A slightly damp cloth is the best cleaning agent for both materials.

- Keep leather clean by dusting weekly or by vacuuming with a soft brush attachment. When cleaning, always use a soft, clean and white cloth.
- If necessary, use a lightly moistened soft cloth with clean lukewarm water and let dry naturally.
- Use only proprietary leather care products suitable for leather.
- Regular use of proprietary leather conditioner recommended.

Do not use any abrasive cleaner or harsh detergent as this can damage the surface. Care for the leather with leather conditioner. We recommend applying leather conditioner before using the furniture for the first time.

Avoid spilling or dropping crumbs of food with a high fat content on the surface as this can permanently mark the leather

GENERAL CARE ADVICE

- Protect from direct sunlight, direct heat and weather fluctuations.
- Make sure the room's humidity is at a normal level.
- Visible screws and bolts must be checked regularly and tightened (if necessary) shortly after purchase. Felt knobs are recommended fitted underneath the legs or bases if the furniture is to be placed on a wooden or parquet floor or surface.
- Vacuum regularly using low suction.
- Clean contact areas of perspiration and body oils regularly.
- Remove all liquid, food dirt and stains immediately.
- Dry naturally away from direct heat. Persistent stains may require treatment by a professional cleaner.

FITTINGS AND PARTS CHECKLIST / DISK BASE

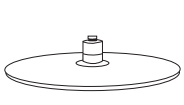
BASE - CHAIR	
A Disk base chair x 1	

MAIN BODY	
B Body x 1	

ASSEMBLED OTTOMAN	
C Assembled Ottoman	

FITTINGS AND PARTS CHECKLIST / RING BASE

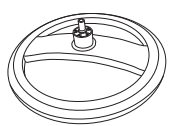
BASE - CHAIR	
A Ring base chair x 1	

MAIN BODY	
B Body x 1	

ASSEMBLED OTTOMAN	
C Assembled Ottoman	

FITTINGS AND PARTS CHECKLIST / STAR BASE

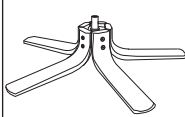
BASE - CHAIR	
A Star base chair x 1	

MAIN BODY	
B Body x 1	

ASSEMBLED OTTOMAN	
C Assembled Ottoman	

STEP BY STEP ASSEMBLY INSTRUCTIONS

STEP 1
Begin by putting body (B) on the already assembled disk base (A).

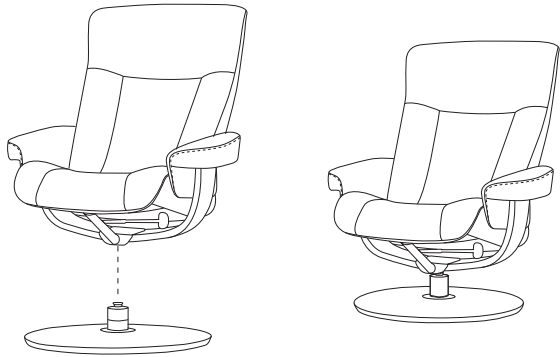

STEP BY STEP ASSEMBLY INSTRUCTIONS

STEP 1
Begin by putting body (B) on the already assembled disk base (A).

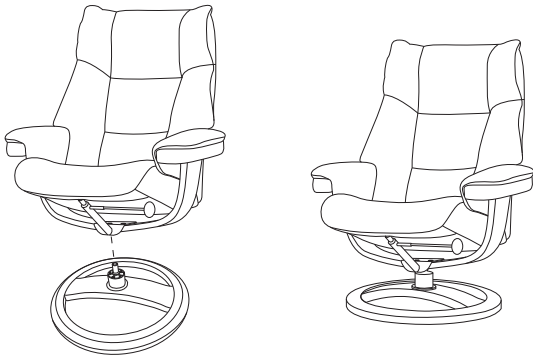

STEP BY STEP ASSEMBLY INSTRUCTIONS

STEP 1
Begin by putting body (B) on the already assembled chair base.



CONGRATULATIONS YOUR CHAIR AND OTTOMAN IS READY TO ENJOY.
NB : Please check bolts for tightness every six months or as needed.

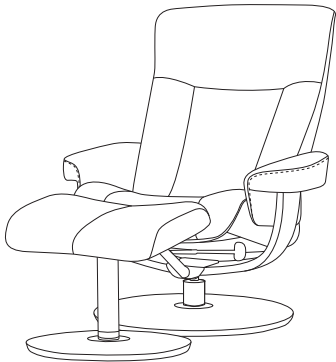

CONGRATULATIONS YOUR CHAIR AND OTTOMAN IS READY TO ENJOY.
NB : Please check bolts for tightness every six months or as needed.



CONGRATULATIONS YOUR CHAIR AND OTTOMAN IS READY TO ENJOY.
NB : Please check bolts for tightness every six months or as needed.

